

LOW VOLTAGE SMD VARISTORS - ZV SERIES

Description

The ZV series of low voltage varistors is designed to protect sensitive electronic devices against high voltage surges in the low voltage region. They offer excellent transient energy absorption due to improved energy volume distribution and power dissipation. Low voltage varistors cover a wide DC operating voltage range from 3 V to 170 V.

ZV varistors are typically applied to protect integrated circuits and other components at the circuit board level.

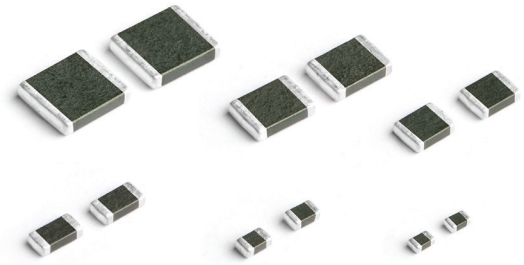

Features

- Operating voltage range V_{dc}3 V to 170 V higher operating voltages available upon request.
- + 125 °C maximum continuous operating temperature
- Varistors with lower or higher capacitance, as well as varistors with a 100 % controlled capacitance value, are available upon request.
- 6 models sizes are available... 0603, 0805, 1206, 1210, 1812, 2220.
- Short response time.
- Broad range of current and energy handling capabilities
- Low clamping voltage – U_c .
- Non-sensitive to mildly activated fluxes (see Soldering Recommendations, page 25).
- End termination: AgPd, AgPdPt or barrier type suitable for Pb-free soldering process – barrier type and terminations solderable with Pb-free solders according to JEDEC J-STD-020C and IEC 60068-2-58.

-  UL 1499, 3rd edition & CSA C22.2 File E326499 Section 8.
- RoHS 2 compliant components according to 2011/65/EC and 2003/11/EC.
- AEC-Q200 qualified Grade 1.

Applications

- Suppression of inductive switching or other transient events such as surge voltage at the circuit board level.
- ESD protection for components sensitive to IEC 1000-4-2, MIL-STD 883C Method 3015.7 and other industry spec.
- Replace larger surface mount TVS Zeners in many applications.
- Used to achieve electromagnetic compliance of end products.
- Provides on-board transient voltage protection of ICs and transistors.

Absolute Maximum Ratings

| | Units | Value |
|--|-------|---------------|
| Continuous: | | |
| Steady State Applied Voltage: | | |
| DC Voltage Range (V_{dc}) | V | 3 to 170 |
| AC Voltage Range (V_{rms}) | V | 2 to 130 |
| Transient: | | |
| Peak Single Pulse Surge Current, 8/20 μ s Waveform (I_{max}) | A | 30 to 1200 |
| Single Pulse Surge Energy, 10/1000 μ s Waveform (W_{max}) | J | 0,1 to 12,2 |
| Operating Ambient Temperature | °C | -55 to +125 |
| Storage Temperature Range | °C | -55 to +150 |
| Threshold Voltage Temperature Coefficient | %/°C | < + 0,05 |
| Response Time | ns | < 2 |
| Climatic Category | | 55 / 125 / 56 |

Device Ratings and Characteristics

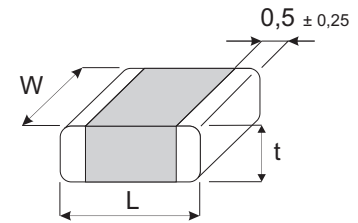

ZV 2 M 0603 300...ZV 20 K 2220 122

| Type | V _{rms} V | V _{dc} V | V _n 1 mA V | V _c V | I _c 8/20 μs A | W _{max} 10/1000 μs J | P max W | I _{max} 8/20 μs A | C _{typ} @ 1 kHz pF | L _{typ} 100 mA/ns nH | L mm | W mm | t max mm |
|------------------|-----------------------|----------------------|-----------------------------|---------------------|--------------------------------|-------------------------------------|---------------|----------------------------------|-----------------------------------|-------------------------------------|------------|-------------|----------------|
| ZV 2 M 0603 300 | 2 | 3 | 4 | 10 | 1 | 0,1 | 0,003 | 30 | 360 | 1,0 | 1,6 ± 0,20 | 0,80 ± 0,10 | 0,95 |
| ZV 2 M 0805 101 | 2 | 3 | 4 | 10 | 1 | 0,1 | 0,005 | 100 | 930 | 1,5 | 2,0 ± 0,25 | 1,25 ± 0,20 | 0,80 |
| ZV 2 M 1206 151 | 2 | 3 | 4 | 10 | 1 | 0,2 | 0,008 | 150 | 4000 | 1,8 | 3,2 ± 0,30 | 1,60 ± 0,20 | 0,85 |
| ZV 4 M 0603 300 | 4 | 5,5 | 8 | 14 | 1 | 0,1 | 0,003 | 30 | 295 | 1,0 | 1,6 ± 0,20 | 0,80 ± 0,10 | 0,95 |
| ZV 4 M 0805 101 | 4 | 5,5 | 8 | 14 | 1 | 0,1 | 0,005 | 100 | 695 | 1,5 | 2,0 ± 0,25 | 1,25 ± 0,20 | 0,80 |
| ZV 4 M 1206 151 | 4 | 5,5 | 8 | 14 | 1 | 0,3 | 0,008 | 150 | 3300 | 1,8 | 3,2 ± 0,30 | 1,60 ± 0,20 | 0,85 |
| ZV 4 M 1210 251 | 4 | 5,5 | 8 | 14 | 3 | 0,4 | 0,010 | 250 | 5000 | 1,8 | 3,2 ± 0,30 | 2,50 ± 0,25 | 0,85 |
| ZV 4 M 1812 501 | 4 | 5,5 | 8 | 14 | 5 | 0,8 | 0,015 | 500 | 10000 | 2,5 | 4,7 ± 0,40 | 3,20 ± 0,30 | 1,25 |
| ZV 4 M 2220 102 | 4 | 5,5 | 8 | 14 | 10 | 1,5 | 0,020 | 1000 | 19500 | 3,0 | 5,7 ± 0,50 | 5,00 ± 0,40 | 1,25 |
| ZV 6 M 0603 300 | 6 | 8 | 11 | 21 | 1 | 0,1 | 0,003 | 30 | 260 | 1,0 | 1,6 ± 0,20 | 0,80 ± 0,10 | 0,95 |
| ZV 6 M 0805 101 | 6 | 8 | 11 | 21 | 1 | 0,2 | 0,005 | 100 | 560 | 1,5 | 2,0 ± 0,25 | 1,25 ± 0,20 | 0,80 |
| ZV 6 M 1206 151 | 6 | 8 | 11 | 21 | 1 | 0,5 | 0,008 | 150 | 2600 | 1,8 | 3,2 ± 0,30 | 1,60 ± 0,20 | 0,85 |
| ZV 6 M 1210 301 | 6 | 8 | 11 | 21 | 3 | 0,8 | 0,010 | 300 | 4100 | 1,8 | 3,2 ± 0,30 | 2,50 ± 0,25 | 0,85 |
| ZV 6 M 1812 501 | 6 | 8 | 11 | 21 | 5 | 1,0 | 0,015 | 500 | 7500 | 2,5 | 4,7 ± 0,40 | 3,20 ± 0,30 | 1,25 |
| ZV 6 M 2220 122 | 6 | 8 | 11 | 21 | 10 | 3,8 | 0,020 | 1200 | 17000 | 3,0 | 5,7 ± 0,50 | 5,00 ± 0,40 | 1,25 |
| ZV 8 L 0603 300 | 8 | 11 | 15 | 25 | 1 | 0,1 | 0,003 | 30 | 240 | 1,0 | 1,6 ± 0,20 | 0,80 ± 0,10 | 0,95 |
| ZV 8 L 0805 121 | 8 | 11 | 15 | 25 | 1 | 0,2 | 0,005 | 120 | 475 | 1,5 | 2,0 ± 0,25 | 1,25 ± 0,20 | 0,80 |
| ZV 8 L 1206 201 | 8 | 11 | 15 | 25 | 1 | 0,6 | 0,008 | 200 | 2000 | 1,8 | 3,2 ± 0,30 | 1,60 ± 0,20 | 0,85 |
| ZV 8 L 1210 401 | 8 | 11 | 15 | 25 | 3 | 1,1 | 0,010 | 400 | 3400 | 1,8 | 3,2 ± 0,30 | 2,50 ± 0,25 | 0,85 |
| ZV 8 L 1812 501 | 8 | 11 | 15 | 25 | 5 | 1,9 | 0,015 | 500 | 6300 | 2,5 | 4,7 ± 0,40 | 3,20 ± 0,30 | 1,25 |
| ZV 8 L 2220 122 | 8 | 11 | 15 | 25 | 10 | 4,3 | 0,020 | 1200 | 15000 | 3,0 | 5,7 ± 0,50 | 5,00 ± 0,40 | 1,25 |
| ZV 11 K 0603 300 | 11 | 14 | 18 | 33 | 1 | 0,2 | 0,003 | 30 | 210 | 1,0 | 1,6 ± 0,20 | 0,80 ± 0,10 | 0,95 |
| ZV 11 K 0805 121 | 11 | 14 | 18 | 33 | 1 | 0,3 | 0,005 | 120 | 400 | 1,5 | 2,0 ± 0,25 | 1,25 ± 0,20 | 0,80 |
| ZV 11 K 1206 201 | 11 | 14 | 18 | 33 | 1 | 0,6 | 0,008 | 200 | 1300 | 1,8 | 3,2 ± 0,30 | 1,60 ± 0,20 | 0,85 |
| ZV 11 K 1210 401 | 11 | 14 | 18 | 33 | 3 | 1,3 | 0,010 | 400 | 2600 | 1,8 | 3,2 ± 0,30 | 2,50 ± 0,25 | 0,85 |
| ZV 11 K 1812 801 | 11 | 14 | 18 | 33 | 5 | 2,0 | 0,015 | 800 | 5100 | 2,5 | 4,7 ± 0,40 | 3,20 ± 0,30 | 1,25 |
| ZV 11 K 2220 122 | 11 | 14 | 18 | 33 | 10 | 5,5 | 0,020 | 1200 | 12000 | 3,0 | 5,7 ± 0,50 | 5,00 ± 0,40 | 1,25 |
| ZV 14 K 0603 300 | 14 | 18 | 22 | 38 | 1 | 0,3 | 0,003 | 30 | 195 | 1,0 | 1,6 ± 0,20 | 0,80 ± 0,10 | 0,95 |
| ZV 14 K 0805 121 | 14 | 18 | 22 | 38 | 1 | 0,4 | 0,005 | 120 | 355 | 1,5 | 2,0 ± 0,25 | 1,25 ± 0,20 | 0,80 |
| ZV 14 K 1206 201 | 14 | 18 | 22 | 38 | 1 | 0,6 | 0,008 | 200 | 950 | 1,8 | 3,2 ± 0,30 | 1,60 ± 0,20 | 0,85 |
| ZV 14 K 1210 401 | 14 | 18 | 22 | 38 | 3 | 1,6 | 0,010 | 400 | 2000 | 1,8 | 3,2 ± 0,30 | 2,50 ± 0,25 | 0,85 |
| ZV 14 K 1812 801 | 14 | 18 | 22 | 38 | 5 | 2,4 | 0,015 | 800 | 4200 | 2,5 | 4,7 ± 0,40 | 3,20 ± 0,30 | 1,25 |
| ZV 14 K 2220 122 | 14 | 18 | 22 | 38 | 10 | 6,0 | 0,020 | 1200 | 9400 | 3,0 | 5,7 ± 0,50 | 5,00 ± 0,40 | 1,25 |
| ZV 17 K 0603 300 | 17 | 22 | 27 | 44 | 1 | 0,3 | 0,003 | 30 | 185 | 1,0 | 1,6 ± 0,20 | 0,80 ± 0,10 | 0,95 |
| ZV 17 K 0805 121 | 17 | 22 | 27 | 44 | 1 | 0,4 | 0,005 | 120 | 315 | 1,5 | 2,0 ± 0,25 | 1,25 ± 0,20 | 0,80 |
| ZV 17 K 1206 201 | 17 | 22 | 27 | 44 | 1 | 0,7 | 0,008 | 200 | 740 | 1,8 | 3,2 ± 0,30 | 1,60 ± 0,20 | 0,85 |
| ZV 17 K 1210 401 | 17 | 22 | 27 | 44 | 3 | 1,8 | 0,010 | 400 | 1700 | 1,8 | 3,2 ± 0,30 | 2,50 ± 0,25 | 0,85 |
| ZV 17 K 1812 801 | 17 | 22 | 27 | 44 | 5 | 2,8 | 0,015 | 800 | 3500 | 2,5 | 4,7 ± 0,40 | 3,20 ± 0,30 | 1,25 |
| ZV 17 K 2220 122 | 17 | 22 | 27 | 44 | 10 | 7,5 | 0,020 | 1200 | 7700 | 3,0 | 5,7 ± 0,50 | 5,00 ± 0,40 | 1,25 |
| ZV 20 K 0603 300 | 20 | 26 | 33 | 54 | 1 | 0,3 | 0,003 | 30 | 175 | 1,0 | 1,6 ± 0,20 | 0,80 ± 0,10 | 0,95 |
| ZV 20 K 0805 121 | 20 | 26 | 33 | 54 | 1 | 0,4 | 0,005 | 120 | 290 | 1,5 | 2,0 ± 0,25 | 1,25 ± 0,20 | 1,05 |
| ZV 20 K 1206 201 | 20 | 26 | 33 | 54 | 1 | 0,8 | 0,008 | 200 | 620 | 1,8 | 3,2 ± 0,30 | 1,60 ± 0,20 | 1,25 |
| ZV 20 K 1210 401 | 20 | 26 | 33 | 54 | 3 | 2,0 | 0,010 | 400 | 1400 | 1,8 | 3,2 ± 0,30 | 2,50 ± 0,25 | 1,35 |
| ZV 20 K 1812 801 | 20 | 26 | 33 | 54 | 5 | 3,0 | 0,015 | 800 | 3000 | 2,5 | 4,7 ± 0,40 | 3,20 ± 0,30 | 1,55 |
| ZV 20 K 2220 122 | 20 | 26 | 33 | 54 | 10 | 8,0 | 0,020 | 1200 | 6500 | 3,0 | 5,7 ± 0,50 | 5,00 ± 0,40 | 1,45 |

Device Ratings and Characteristics

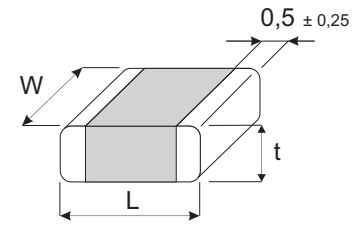

ZV 25 K 0603 300....ZV 130 K 2220 501

| Type | V _{rms} V | V _{dc} V | V _n 1 mA V | V _c V | I _c 8/20 μs A | W _{max} 10/1000 μs J | P max W | I _{max} 8/20 μs A | C _{typ} @ 1 kHz pF | L _{typ} 100 mA/ns nH | L mm | W mm | t max mm |
|-------------------|-----------------------|----------------------|-----------------------------|---------------------|--------------------------------|-------------------------------------|---------------|----------------------------------|-----------------------------------|-------------------------------------|------------|-------------|----------------|
| ZV 25 K 0603 300 | 25 | 31 | 39 | 65 | 1 | 0,1 | 0,003 | 30 | 165 | 1,0 | 1,6 ± 0,20 | 0,80 ± 0,10 | 0,95 |
| ZV 25 K 0805 121 | 25 | 31 | 39 | 65 | 1 | 0,2 | 0,005 | 120 | 260 | 1,5 | 2,0 ± 0,25 | 1,25 ± 0,20 | 1,05 |
| ZV 25 K 1206 201 | 25 | 31 | 39 | 65 | 1 | 1,0 | 0,008 | 200 | 510 | 1,8 | 3,2 ± 0,30 | 1,60 ± 0,20 | 1,25 |
| ZV 25 K 1210 401 | 25 | 31 | 39 | 65 | 3 | 1,8 | 0,010 | 400 | 1060 | 1,8 | 3,2 ± 0,30 | 2,50 ± 0,25 | 1,45 |
| ZV 25 K 1812 801 | 25 | 31 | 39 | 65 | 5 | 3,9 | 0,015 | 800 | 2300 | 2,5 | 4,7 ± 0,40 | 3,20 ± 0,30 | 1,55 |
| ZV 25 K 2220 122 | 25 | 31 | 39 | 65 | 10 | 9,5 | 0,020 | 1200 | 5000 | 3,0 | 5,7 ± 0,50 | 5,00 ± 0,40 | 1,45 |
| ZV 30 K 0603 300 | 30 | 38 | 47 | 77 | 1 | 0,1 | 0,003 | 30 | 160 | 1,0 | 1,6 ± 0,20 | 0,80 ± 0,10 | 0,95 |
| ZV 30 K 0805 121 | 30 | 38 | 47 | 77 | 1 | 0,2 | 0,005 | 120 | 230 | 1,5 | 2,0 ± 0,25 | 1,25 ± 0,20 | 1,05 |
| ZV 30 K 1206 201 | 30 | 38 | 47 | 77 | 1 | 1,2 | 0,008 | 200 | 450 | 1,8 | 3,2 ± 0,30 | 1,60 ± 0,20 | 1,25 |
| ZV 30 K 1210 301 | 30 | 38 | 47 | 77 | 3 | 2,1 | 0,010 | 300 | 850 | 1,8 | 3,2 ± 0,30 | 2,50 ± 0,25 | 1,45 |
| ZV 30 K 1812 801 | 30 | 38 | 47 | 77 | 5 | 4,4 | 0,015 | 800 | 1800 | 2,5 | 4,7 ± 0,40 | 3,20 ± 0,30 | 1,55 |
| ZV 30 K 2220 122 | 30 | 38 | 47 | 77 | 10 | 12,2 | 0,020 | 1200 | 4000 | 3,0 | 5,7 ± 0,50 | 5,00 ± 0,40 | 1,45 |
| ZV 35 K 1206 121 | 35 | 45 | 56 | 90 | 1 | 0,6 | 0,008 | 120 | 400 | 1,8 | 3,2 ± 0,30 | 1,60 ± 0,20 | 1,25 |
| ZV 35 K 1210 251 | 35 | 45 | 56 | 90 | 3 | 2,2 | 0,010 | 250 | 670 | 1,8 | 3,2 ± 0,30 | 2,50 ± 0,25 | 1,45 |
| ZV 35 K 1812 601 | 35 | 45 | 56 | 90 | 5 | 4,2 | 0,015 | 600 | 1340 | 2,5 | 4,7 ± 0,40 | 3,20 ± 0,30 | 1,55 |
| ZV 35 K 2220 102 | 35 | 45 | 56 | 90 | 10 | 7,6 | 0,020 | 1000 | 3000 | 3,0 | 5,7 ± 0,50 | 5,00 ± 0,40 | 1,45 |
| ZV 40 K 1206 121 | 40 | 56 | 68 | 110 | 1 | 0,8 | 0,008 | 120 | 370 | 1,8 | 3,2 ± 0,30 | 1,60 ± 0,20 | 1,25 |
| ZV 40 K 1210 251 | 40 | 56 | 68 | 110 | 3 | 2,4 | 0,010 | 250 | 570 | 1,8 | 3,2 ± 0,30 | 2,50 ± 0,25 | 1,45 |
| ZV 40 K 1812 601 | 40 | 56 | 68 | 110 | 5 | 4,8 | 0,015 | 600 | 1000 | 2,5 | 4,7 ± 0,40 | 3,20 ± 0,30 | 1,55 |
| ZV 40 K 2220 102 | 40 | 56 | 68 | 110 | 10 | 9,2 | 0,020 | 1000 | 2200 | 3,0 | 5,7 ± 0,50 | 5,00 ± 0,40 | 1,45 |
| ZV 50 K 1206 121 | 50 | 65 | 82 | 135 | 1 | 0,8 | 0,008 | 120 | 340 | 1,8 | 3,2 ± 0,30 | 1,60 ± 0,20 | 1,65 |
| ZV 50 K 1210 251 | 50 | 65 | 82 | 135 | 3 | 1,7 | 0,010 | 250 | 470 | 1,8 | 3,2 ± 0,30 | 2,50 ± 0,25 | 1,75 |
| ZV 50 K 1812 401 | 50 | 65 | 82 | 135 | 5 | 4,8 | 0,015 | 400 | 710 | 2,5 | 4,7 ± 0,40 | 3,20 ± 0,30 | 1,85 |
| ZV 50 K 2220 801 | 50 | 65 | 82 | 135 | 10 | 5,8 | 0,020 | 800 | 1500 | 3,0 | 5,7 ± 0,50 | 5,00 ± 0,40 | 1,85 |
| ZV 60 K 1206 121 | 60 | 85 | 100 | 165 | 1 | 0,9 | 0,008 | 120 | 330 | 1,8 | 3,2 ± 0,30 | 1,60 ± 0,20 | 1,65 |
| ZV 60 K 1210 251 | 60 | 85 | 100 | 165 | 3 | 2,2 | 0,010 | 250 | 390 | 1,8 | 3,2 ± 0,30 | 2,50 ± 0,25 | 1,75 |
| ZV 60 K 1812 401 | 60 | 85 | 100 | 165 | 5 | 5,8 | 0,015 | 400 | 580 | 2,5 | 4,7 ± 0,40 | 3,20 ± 0,30 | 1,85 |
| ZV 60 K 2220 801 | 60 | 85 | 100 | 165 | 10 | 6,2 | 0,020 | 800 | 1000 | 3,0 | 5,7 ± 0,50 | 5,00 ± 0,40 | 1,85 |
| ZV 75 K 1206 121 | 75 | 100 | 120 | 200 | 1 | 0,9 | 0,008 | 120 | 240 | 1,8 | 3,2 ± 0,30 | 1,60 ± 0,20 | 1,70 |
| ZV 75 K 1210 251 | 75 | 100 | 120 | 200 | 3 | 2,2 | 0,010 | 250 | 330 | 1,8 | 3,2 ± 0,30 | 2,50 ± 0,25 | 1,80 |
| ZV 75 K 1812 401 | 75 | 100 | 120 | 200 | 5 | 5,8 | 0,015 | 400 | 440 | 2,5 | 4,7 ± 0,40 | 3,20 ± 0,30 | 1,90 |
| ZV 75 K 2220 801 | 75 | 100 | 120 | 200 | 10 | 6,2 | 0,020 | 800 | 700 | 3,0 | 5,7 ± 0,50 | 5,00 ± 0,40 | 1,90 |
| ZV 95 K 1210 201 | 95 | 125 | 150 | 250 | 3 | 2,6 | 0,010 | 200 | 240 | 1,8 | 3,2 ± 0,30 | 2,50 ± 0,25 | 1,80 |
| ZV 95 K 1812 301 | 95 | 125 | 150 | 250 | 5 | 5,2 | 0,015 | 300 | 340 | 2,5 | 4,7 ± 0,40 | 3,20 ± 0,30 | 1,90 |
| ZV 95 K 2220 501 | 95 | 125 | 150 | 250 | 10 | 7,4 | 0,020 | 500 | 600 | 3,0 | 5,7 ± 0,50 | 5,00 ± 0,40 | 1,90 |
| ZV 115 K 1210 201 | 115 | 150 | 180 | 300 | 3 | 2,6 | 0,010 | 200 | 200 | 1,8 | 3,2 ± 0,30 | 2,50 ± 0,25 | 1,80 |
| ZV 115 K 1812 301 | 115 | 150 | 180 | 300 | 5 | 5,2 | 0,015 | 300 | 310 | 2,5 | 4,7 ± 0,40 | 3,20 ± 0,30 | 1,90 |
| ZV 115 K 2220 501 | 115 | 150 | 180 | 300 | 10 | 7,4 | 0,020 | 500 | 560 | 3,0 | 5,7 ± 0,50 | 5,00 ± 0,40 | 1,90 |
| ZV 130 K 1210 201 | 130 | 170 | 205 | 340 | 3 | 2,6 | 0,010 | 200 | 150 | 1,8 | 3,2 ± 0,30 | 2,50 ± 0,25 | 1,80 |
| ZV 130 K 1812 301 | 130 | 170 | 205 | 340 | 5 | 5,2 | 0,015 | 300 | 240 | 2,5 | 4,7 ± 0,40 | 3,20 ± 0,30 | 1,90 |
| ZV 130 K 2220 501 | 130 | 170 | 205 | 340 | 10 | 7,4 | 0,020 | 500 | 500 | 3,0 | 5,7 ± 0,50 | 5,00 ± 0,40 | 1,90 |

KEKO VARICON products are sold by description only - product technical specification. KEKO VARICON reserves the right to make changes in circuit design and/or specifications at any time without notice. Accordingly the reader is cautioned to verify that data sheets are current before placing orders. Information furnished by KEKO VARICON is believed to be accurate and reliable. However, no responsibility is assumed by KEKO VARICON for its use; nor for any infringements of patents or other rights of third parties which may result from its use.

Protection Level

* With the worst-case condition in the tolerance region

Model Size 0603
ZV 2 M ... 30K

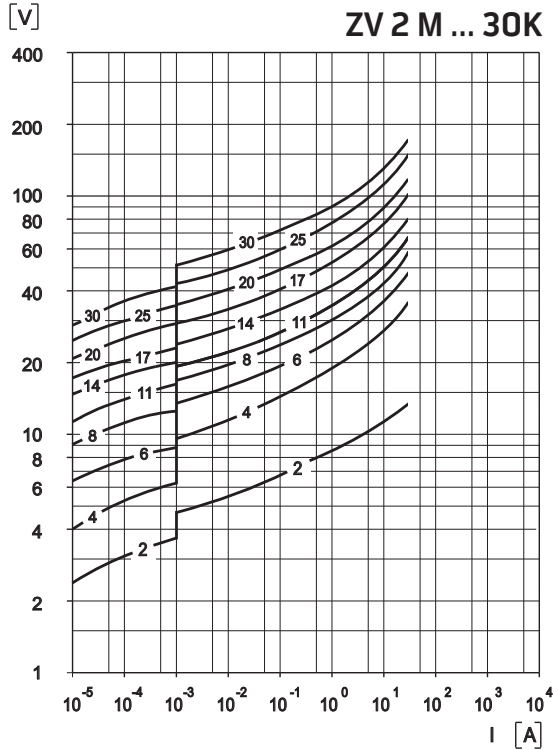

Model Size 0805
ZV 2 M ... 30 K

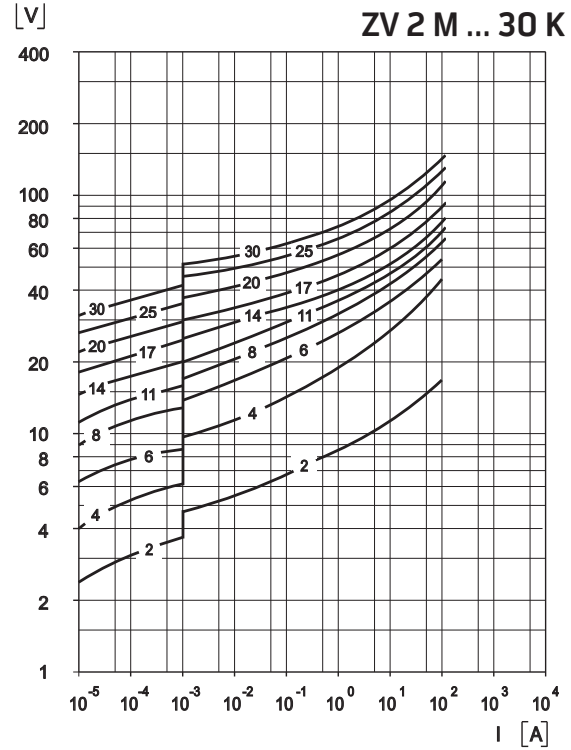

Model Size 1206
ZV 2 M ... 60K

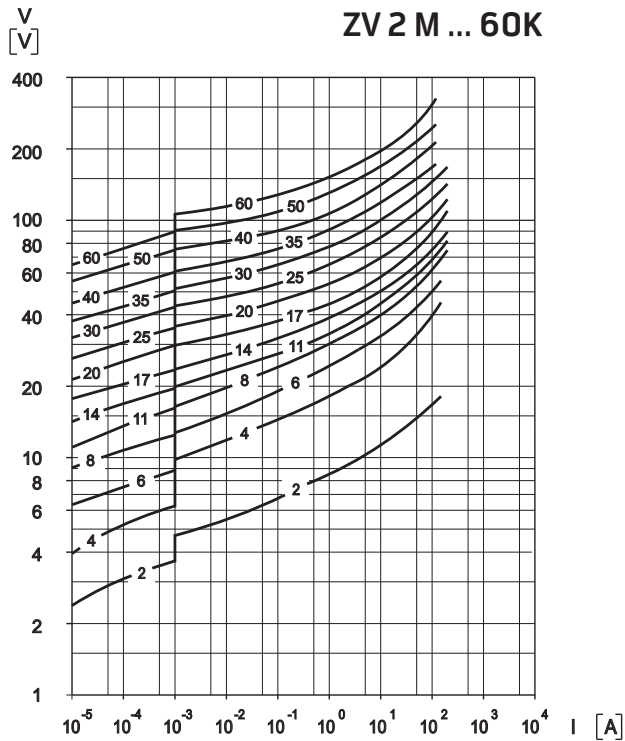

Model Size 1210
ZV 4 M ... 95 K

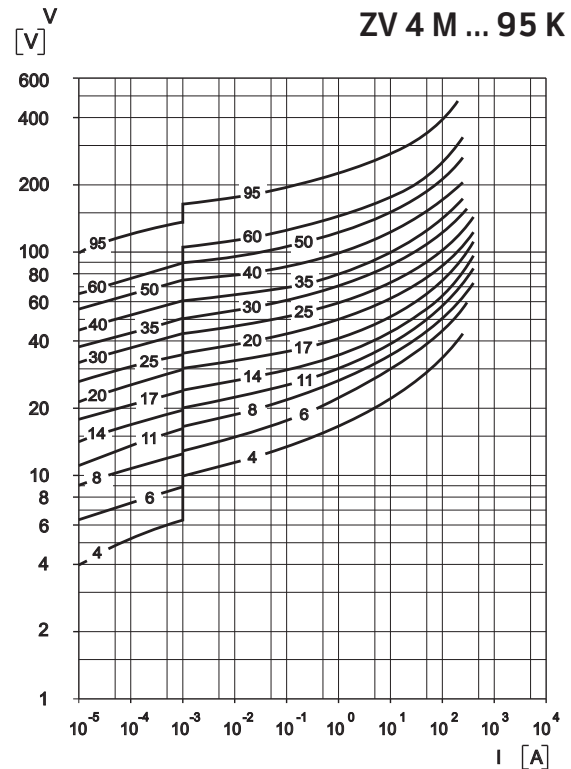

KEKO VARICON products are sold by description only - product technical specification. KEKO VARICON reserves the right to make changes in circuit design and/or specifications at any time without notice. Accordingly the reader is cautioned to verify that data sheets are current before placing orders. Information furnished by KEKO VARICON is believed to be accurate and reliable. However, no responsibility is assumed by KEKO VARICON for its use; nor for any infringements of patents or other rights of third parties which may result from its use.

Protection Level

* With the worst-case condition in the tolerance region

Model Size 1812
ZV 4 M ... 95K

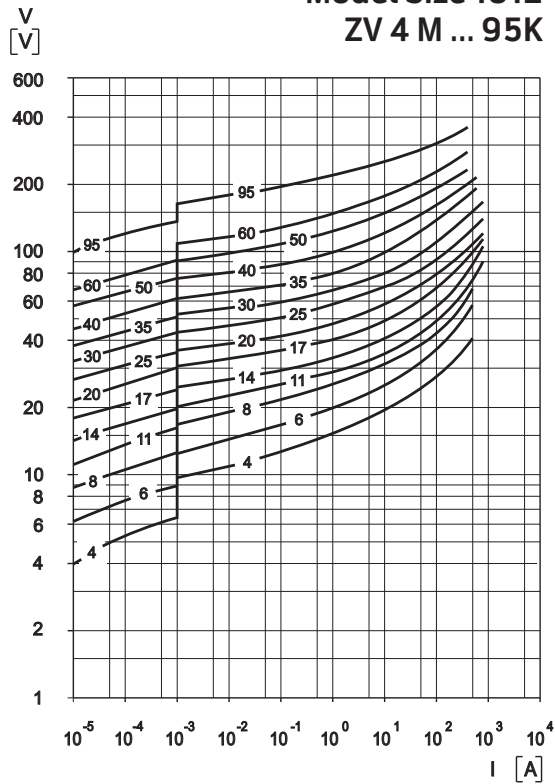

Model Size 222
ZV 4 M ... 95 K

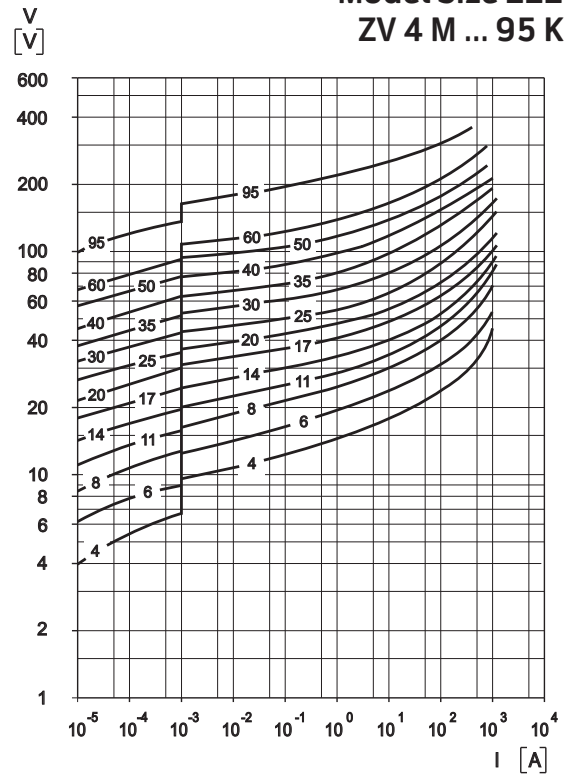

Pulse Rating Curves

ZV 6 M ... 30 K 2220 122

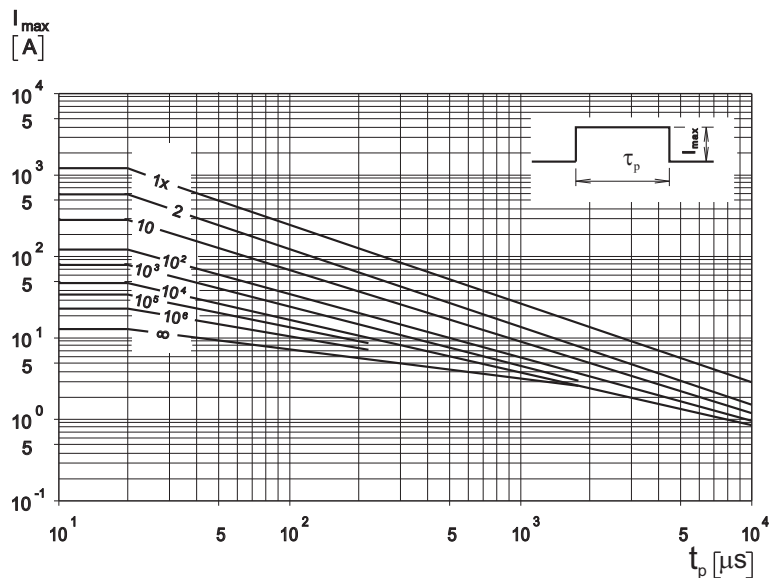

KEKO VARICON products are sold by description only - product technical specification. KEKO VARICON reserves the right to make changes in circuit design and/or specifications at any time without notice. Accordingly the reader is cautioned to verify that data sheets are current before placing orders. Information furnished by KEKO VARICON is believed to be accurate and reliable. However, no responsibility is assumed by KEKO VARICON for its use; nor for any infringements of patents or other rights of third parties which may result from its use.

Pulse Rating Curves

ZV 2 M...30 K 0603 300

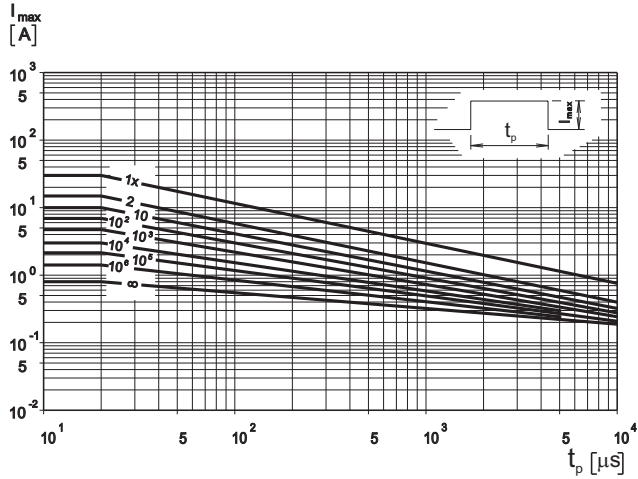

ZV 2 M...6 M 0805 101

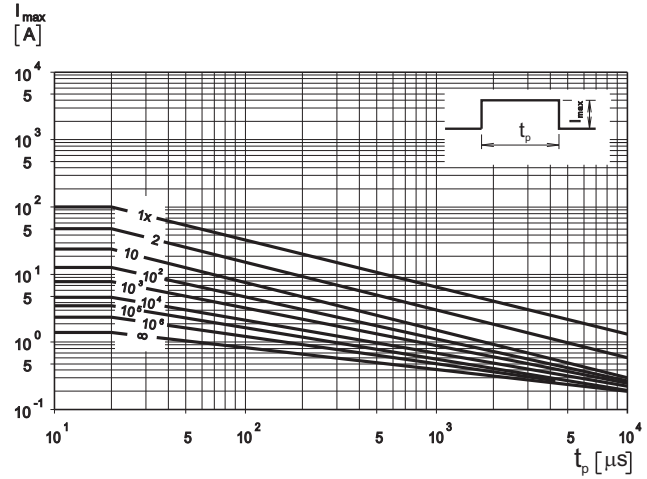

ZV 8 L...30 K 0805 121
ZV 35 K...60 K 1206 121

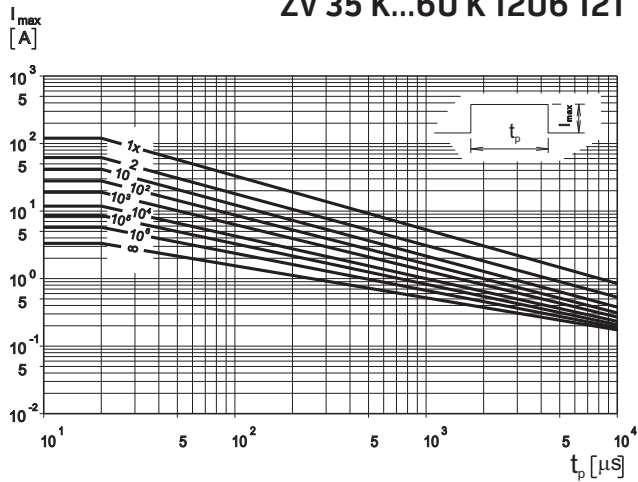

ZV 2 M...6 M 1206 151

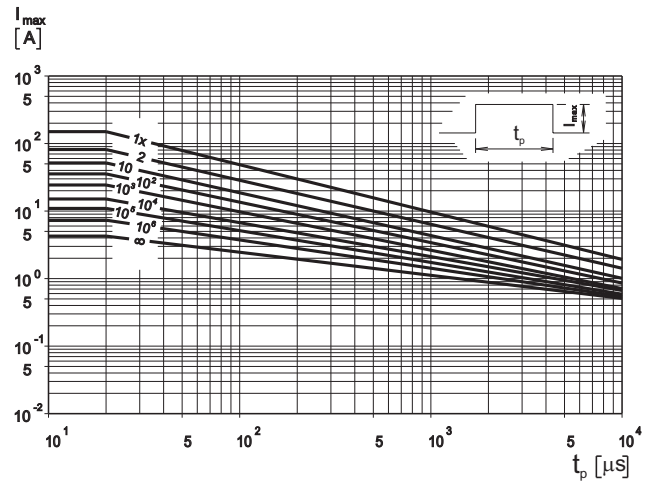

ZV 8 L...30 1206 201
ZV 95 K 1210 201

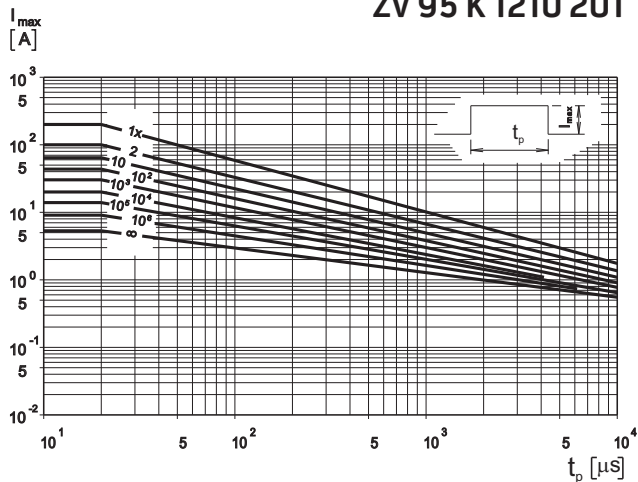

ZV 4 M 1210 251
ZV 35...60 K 1210 251

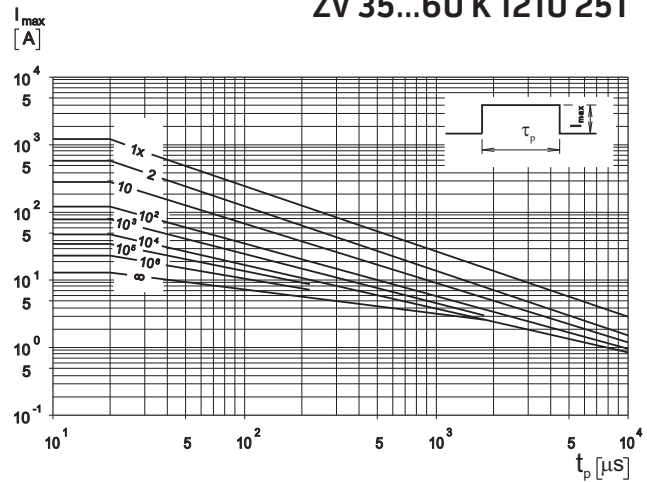

KEKO VARICON products are sold by description only - product technical specification. KEKO VARICON reserves the right to make changes in circuit design and/or specifications at any time without notice. Accordingly the reader is cautioned to verify that data sheets are current before placing orders. Information furnished by KEKO VARICON is believed to be accurate and reliable. However, no responsibility is assumed by KEKO VARICON for its use; nor for any infringements of patents or other rights of third parties which may result from its use.

Pulse Rating Curves

ZV 6 M 1210 301
ZV 30 K 1210 301
ZV 95 K 1812 301

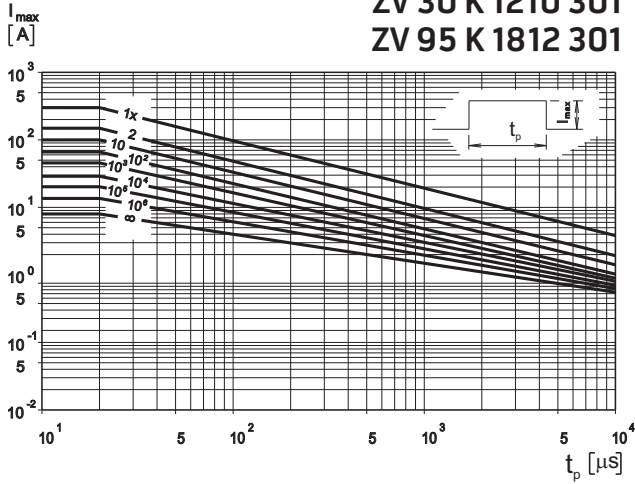

ZV 8 L...25 K 1210 401
ZV 50 K...60 K 1812 401

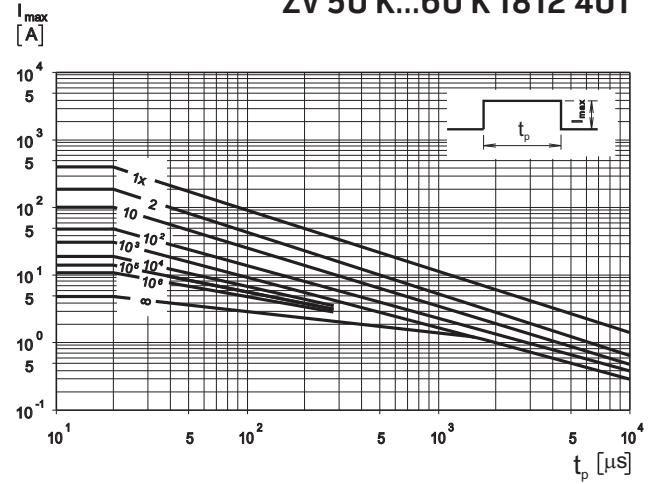

ZV 4 M...8 L 1812 501
ZV 95 K 2220 501

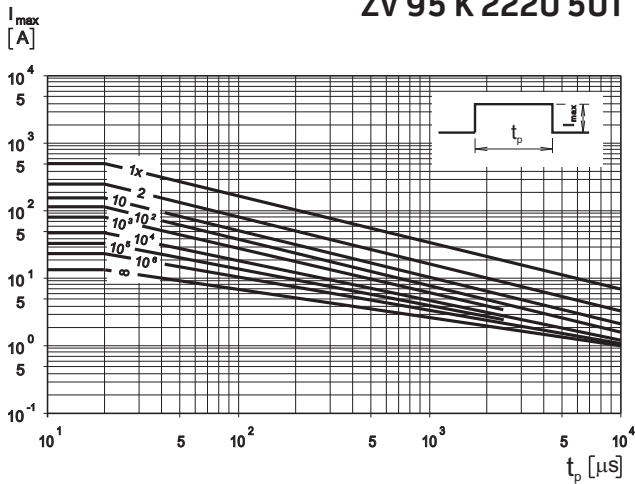

ZV 35 K...40 K 1812 601

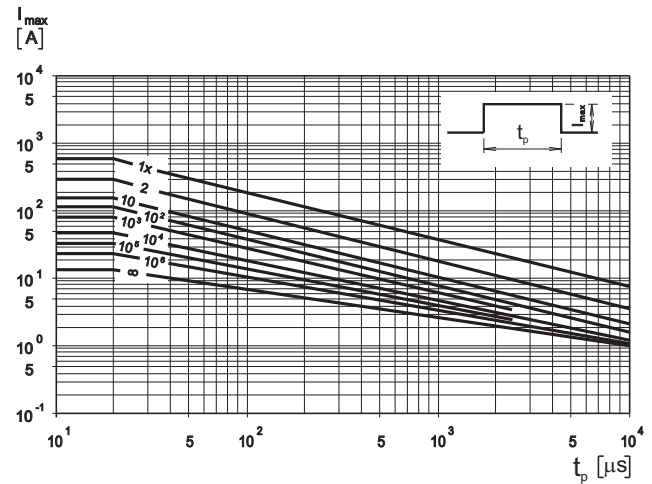

ZV 11 K...30 K 1812 801
ZV 50 K...60 K 2220 801

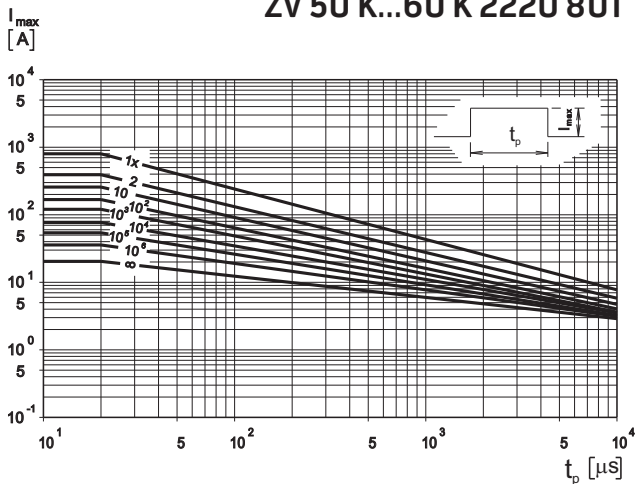

ZV 4 M 2220 102
ZV 35 K...40 K 2220 102

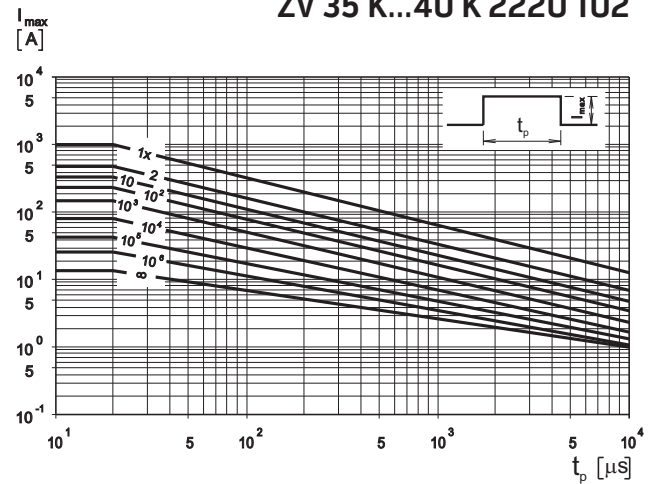

Reliability – Lifetime

In general, **reliability** is the ability of a component to perform and maintain its functions in routine circumstances, as well as in hostile or unexpected circumstances.

The Mean life of ZV series components is a function of:

- - Factor of Applied Voltage
- - Ambient temperature.

Mean life is closely related to Failure rate (formula).

Mean life (ML) is the arithmetic mean (average) time to failure of a component.

Failure rate is the frequency with which an engineered system or component fails, expressed for example in failures per hour. Failure rate is usually time dependent, and an intuitive corollary is that the rate changes over time versus the expected life cycle of a system.

Failure rate formula – calculation

$$\Lambda = \frac{10^9}{ML [h]} \text{ [fit]}$$

FAV – Factor of Applied Voltage

$$FAV = \frac{V_{apl}}{V_{max}}$$

V_{apl} ... applied voltage

V_{max} ... maximum operating voltage

ZV 2 ... 130 Dimension 0603 ... 2220

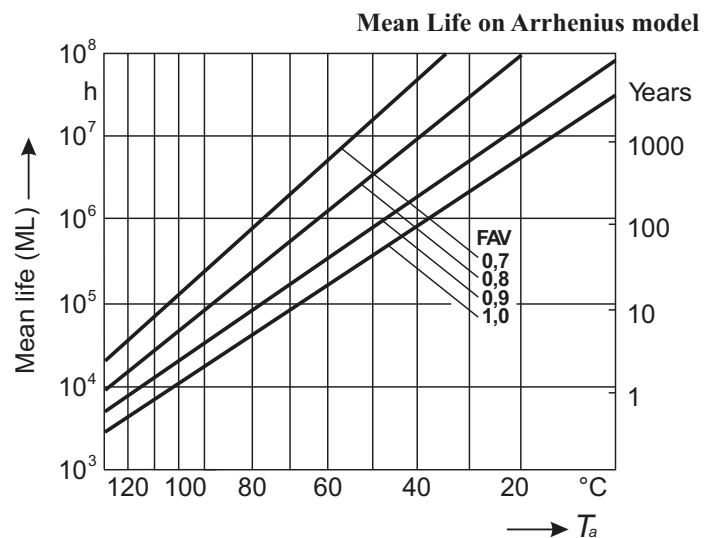

Soldering Pad Configuration

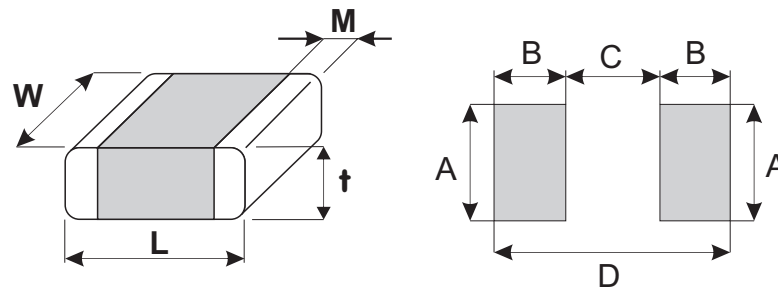

| Size | L (mm) | W (mm) | M (mm) | t_{\max} (mm) | A (mm) | B (mm) | C (mm) | D (mm) |
|-------------|------------|-------------|------------|--------------------|-----------|-----------|-----------|-----------|
| 0603 | 1,6 ± 0,20 | 0,80 ± 0,10 | 0,5 ± 0,25 | 1,0 | 1,0 | 1,0 | 0,6 | 2,6 |
| 0805 | 2,0 ± 0,25 | 1,25 ± 0,20 | 0,5 ± 0,25 | 1,1 | 1,4 | 1,2 | 1,0 | 3,4 |
| 1206 | 3,2 ± 0,30 | 1,60 ± 0,20 | 0,5 ± 0,25 | 1,6 | 1,8 | 1,2 | 2,1 | 4,5 |
| 1210 | 3,2 ± 0,30 | 2,50 ± 0,25 | 0,5 ± 0,25 | 1,8 | 2,8 | 1,2 | 2,1 | 4,5 |
| 1812 | 4,7 ± 0,40 | 3,20 ± 0,30 | 0,5 ± 0,25 | 1,9 | 3,6 | 1,5 | 3,2 | 6,2 |
| 2220 | 5,7 ± 0,50 | 5,00 ± 0,40 | 0,5 ± 0,25 | 1,9 | 5,5 | 1,5 | 4,2 | 7,2 |
| 3225 | 8,0 ± 0,50 | 6,30 ± 0,40 | 0,5 ± 0,25 | 2,0 | 6,8 | 1,5 | 6,5 | 9,5 |

Tape and Reel Specification

Conforms to IEC Publication 286 - 3 Ed.4: 2007-06

Tape

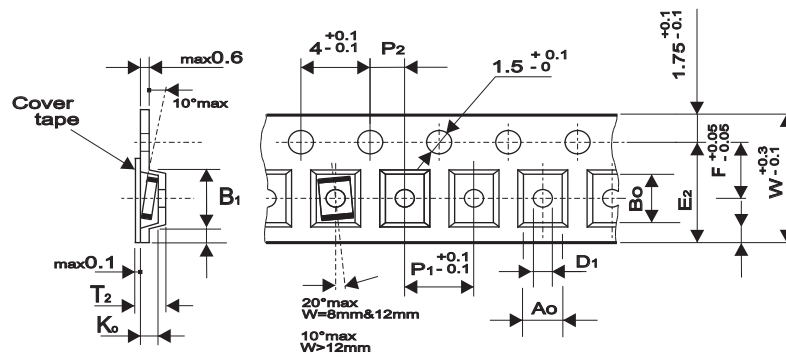

Reel

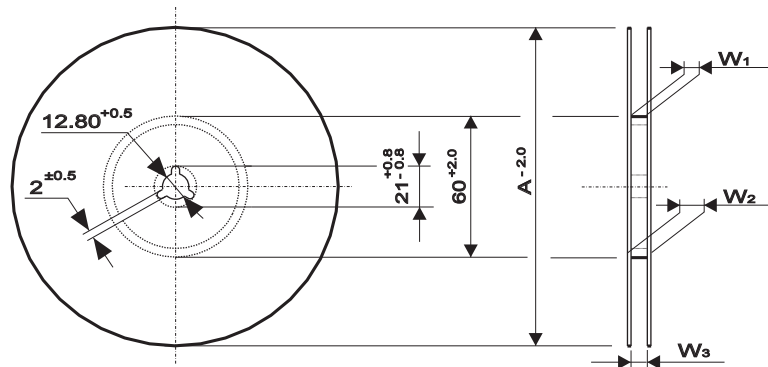

Variable dimensions

| Tape Size | | 8 mm | | | | 12 mm | | 16 mm | |
|-----------|-------|------------|------------|------------|------------|-------------|-------------|-------------|-------------|
| Size | Units | 0603 | 0805 | 1206 | 1210 | 1812 | 2220 | 3225 | 4032 |
| Ao | (mm) | 1,2 | 1,6 | 1,9 | 2,9 | 3,75 | 5,6 | 7 | 8,6 |
| Bo | (mm) | 1,9 | 2,4 | 3,75 | 3,7 | 5 | 6,25 | 8,7 | 10,8 |
| Ko max | (mm) | 1,1 | 1,1 | 1,8 | 2 | 2 | 2 | 3,7 | 3,7 |
| B1 max | (mm) | 4,35 | 4,35 | 4,35 | 4,35 | 8,2 | 8,2 | 12,1 | 12,1 |
| D1 min | (mm) | 0,3 | 0,3 | 0,3 | 0,3 | 1,5 | 1,5 | 1,5 | 1,5 |
| E2 min | (mm) | 6,25 | 6,25 | 6,25 | 6,25 | 10,25 | 10,25 | 14,25 | 14,25 |
| P1 | (mm) | 4 | 4 | 4 | 4 | 8 | 8 | 12 | 12 |
| F | (mm) | 3,5 | 3,5 | 3,5 | 3,5 | 5,5 | 5,5 | 7,5 | 7,5 |
| W | (mm) | 8,0 | 8,0 | 8,0 | 8,0 | 12,0 | 12,0 | 16,0 | 16,0 |
| T2 max | (mm) | 3,5 | 3,5 | 3,5 | 3,5 | 6,5 | 6,5 | 9,5 | 9,5 |
| W1 | (mm) | 8,4+1,5 | 8,4+1,5 | 8,4+1,5 | 8,4+1,5 | 12,4+2 | 12,4+2 | 16,4+2 | 16,4+2 |
| W2 max | (mm) | 14,4 | 14,4 | 14,4 | 14,4 | 18,4 | 18,4 | 22,4 | 22,4 |
| W3 | (mm) | 7,9...10,9 | 7,9...10,9 | 7,9...10,9 | 7,9...10,9 | 11,9...15,4 | 11,9...15,4 | 15,9...19,4 | 15,9...19,4 |
| A | (mm) | 180/330 | 180/330 | 180/330 | 180/330 | 180/330 | 180/330 | 330 | 330 |

Package units

| Series | Voltage range (V) | Chip Size | | | | | | | | | | | | | |
|----------|-------------------|----------------|-------|----------------|-------|----------------|-------|----------------|-------|----------------|------|----------------|------|----------------|----------------|
| | | 0603 Reel size | | 0805 Reel size | | 1206 Reel size | | 1210 Reel size | | 1812 Reel size | | 2220 Reel size | | 3225 Reel size | 4032 Reel size |
| | | 180 | 330 | 180 | 330 | 180 | 330 | 180 | 330 | 180 | 330 | 180 | 330 | 330 | 330 |
| ZVE | 14 | 4000 | 15000 | 4000 | 15000 | 4000 | 15000 | 4000 | 15000 | | | | | | |
| ZV / ZVX | 2 to 14 | 4000 | 15000 | 4000 | 15000 | 4000 | 15000 | 4000 | 15000 | 1500 | 6000 | 1500 | 5000 | | |
| | 17 | 3500 | 14000 | 3500 | 14000 | 2500 | 14000 | 2500 | 14000 | 1500 | 6000 | 1500 | 5000 | | |
| | 20 to 40 | 3500 | 14000 | 3500 | 14000 | 2500 | 10000 | 2500 | 9000 | 1000 | 4000 | 1000 | 4000 | | |
| AV | 50 to 130 | | | | | 2000 | 8000 | 2000 | 8000 | 1000 | 4000 | 1000 | 4000 | | |
| | 14 | | | 3500 | 15000 | 2500 | 15000 | 2500 | 15000 | 1000 | 6000 | 1000 | 4000 | 2500 | 2500 |
| | 17 | | | 3500 | 14000 | 2500 | 14000 | 2500 | 14000 | 1000 | 6000 | 1000 | 4000 | 2500 | 2500 |
| | 20 to 40 | | | | 14000 | 2500 | 10000 | 2500 | 9000 | 1000 | 4000 | 1000 | 4000 | 2500 | 2500 |

KEKO VARICON products are sold by description only - product technical specification. KEKO VARICON reserves the right to make changes in circuit design and/or specifications at any time without notice. Accordingly the reader is cautioned to verify that data sheets are current before placing orders. Information furnished by KEKO VARICON is believed to be accurate and reliable. However, no responsibility is assumed by KEKO VARICON for its use; nor for any infringements of patents or other rights of third parties which may result from its use.

Ordering Information

AV 20 K 1210 401 N R1 yy

AV 20 K 1210 401 Ni R1 yy

AV - Series Name: AV, ZV, ZVE, ZVX

20 - Maximum Continuous Working Voltage - V_{rms}

K - V_n Tolerance: K = $\pm 10\%$, L = $\pm 15\%$, M = $\pm 20\%$

1210 - Chip Size: 0603, 0805, 1206, 1210, 1812, 2220, 3225

401 - Maximum Surge Current: 400 = 40 A; 401 = 400 A

N - Barrier type end terminations suitable for Pb-free reflow soldering
- (no letter) AgPd end terminations suitable for Pb reflow soldering

Ni - Ni Sn barrier type end terminations - suitable for Pb and Pb-Free reflow soldering

R1 - Packaging: R1 = Reel 180 mm, R2 = Reel 330 mm, R3 = 180 mm-1000 pcs

yy - Special requirements

SOLDERING RECOMMENDATIONS

Popular soldering techniques used for surface mounted components are Wave and Infrared Reflow processes. Both processes can be performed with Pb-containing or Pb-free solders. The termination options available for these soldering techniques are AgPd and Barrier Type End Terminations.

| End termination | Designation | Recommended and Suitable for | Component RoHS Compliant |
|------------------------------|---------------------------------------|---------------------------------------|--------------------------|
| Ag/Pd | Series (ZV, AV, DV, C, ...)..... R1 | Pb-containing soldering | Yes |
| Barrier Type End Termination | Series (ZV, AV, DV, C, ...)..... N R1 | Pb-containing and Pb-free soldering | Yes |
| Ni Sn End Termination | Series (ZV, AV, ...) ...Ni R1 | Pb-containing and Pb-free soldering v | Yes |

Wave Soldering – this process is generally associated with discrete components mounted on the underside of printed circuit boards, or for large top-side components with bottom-side mounting tabs to be attached, such as the frames of transformers, relays, connectors, etc. SMD varistors to be wave soldered are first glued to the circuit board, usually with an epoxy adhesive. When all components on the PCB have been positioned and an appropriate time is allowed for adhesive curing, the completed assembly is then placed on a conveyor and run through a single, double wave process.

Infrared Reflow Soldering – these reflow processes are typically associated with top-side component placement. This technique utilizes a mixture of adhesive and solder compounds (and sometimes fluxes) that are blended into a paste. The paste is then screened onto PCB soldering pads specifically designed to accept a particular sized SMD component. The recommended solder paste wet layer thickness is 100 to 300 μm . Once the circuit board is fully populated with MD components, it is placed in a reflow environment, where the paste is heated to slightly above its eutectic temperature. When the solder paste reflows, the SMD components are attached to the solder pads.

Solder Fluxes – solder fluxes are generally applied to populated circuit boards to lean oxides form forming during the heating process and to facilitate the flowing of the solder. Solder fluxes can be either a part of the solder paste compound or can be separate materials, usually fluids. Recommended fluxes are:

- non-activated (R) fluxes, whenever possible
- mildly activated (RMA) fluxes of class L3CN
- class ORLO

Activated (RA), water soluble or strong acidic fluxes with a chlorine content > 0.2 wt. % are NOT RECOMMENDED. The use of such fluxes could create high leakage current paths along the body of the varistor components.

When a flux is applied prior to wave soldering, it is important to completely dry any residual flux solvents prior to the soldering process.

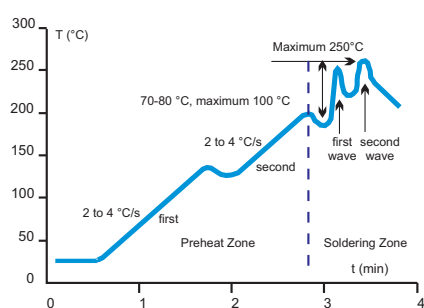

Fig. 1. Wave Soldering Temperature Profile for Pb-free and Pb-containing Soldering

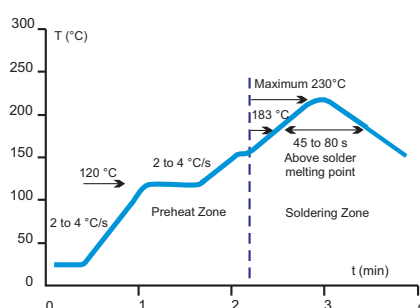

Fig. 2. Infrared Reflow Temperature Profile for Pb-containing Soldering

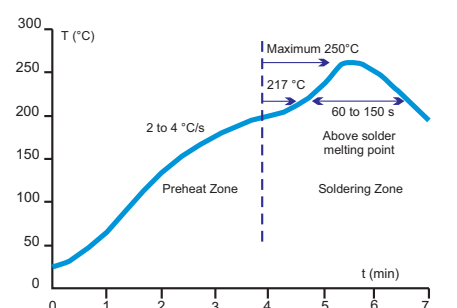

Fig. 3. Reflow Temperature Profile for Pb-free Soldering

Thermal Shock – to avoid the possibility of generating stresses in the varistor chip due to thermal shock, a preheat stage to within 100 °C of the peak soldering process temperature is recommended. Additionally, SMD varistors should not be subjected to a temperature gradient greater than 4 °C/sec., with an ideal gradient being 2 °C/sec. Peak temperatures should be controlled. Wave and Reflow soldering conditions for SMD varistors with Pb-containing solders are shown in Fig. 1 and 2 respectively, while Wave and Reflow soldering conditions for SMD varistors with Pb-free solders are shown in Fig. 1 and 3.

Whenever several different types of SMD components are being soldered, each having a specific soldering profile, the soldering profile with the least heat and the minimum amount of heating time is recommended. Once soldering has been completed, it is necessary to minimize the possibility of thermal shock by allowing the hot PCB to cool to less than 50 °C before cleaning.

Inspection Criteria – the inspection criteria to determine acceptable solder joints, when Wave or Infrared Reflow processes are used, will depend on several key variables, principally termination material process profiles.

Pb-containing Wave and IR Reflow Soldering – typical “before” and “after” soldering results for Silver/Palladium (AgPd) and Barrier Type End Terminations can be seen in Fig. 4. Both barrier type and silver/palladium terminated varistors form a reliable electrical contact and metallurgical bond between the end terminations and the solder pads. The bond between these two metallic surfaces is exceptionally strong and has been tested by both vertical pull and lateral (horizontal) push tests. The results, in both cases, exceed established industry standards for adhesion.

The solder joint appearance of a barrier type terminated versus a silver/palladium terminated varistor will be slightly different. Solder forms a metallurgical junction with the thin tin-alloy (over the barrier layer), and due to its small volume “climbs” the outer surface of the terminations, the meniscus will be slightly lower. This optical appearance difference should be taken into consideration when programming visual inspection of the PCB after soldering.

Silver Palladium (AgPd) End Terminations

Barrier Type End Terminations and Ni Sn End Terminations

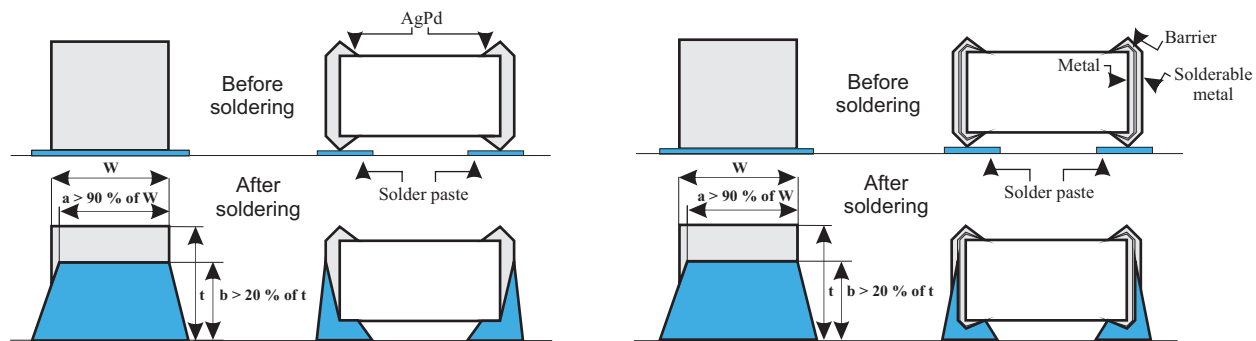

Fig. 4 Soldering Criterion in case of Wave and IR Reflow Pb-containing Soldering

Silver Palladium (AgPd) End Terminations

Barrier Type End Terminations and Ni Sn End Terminations

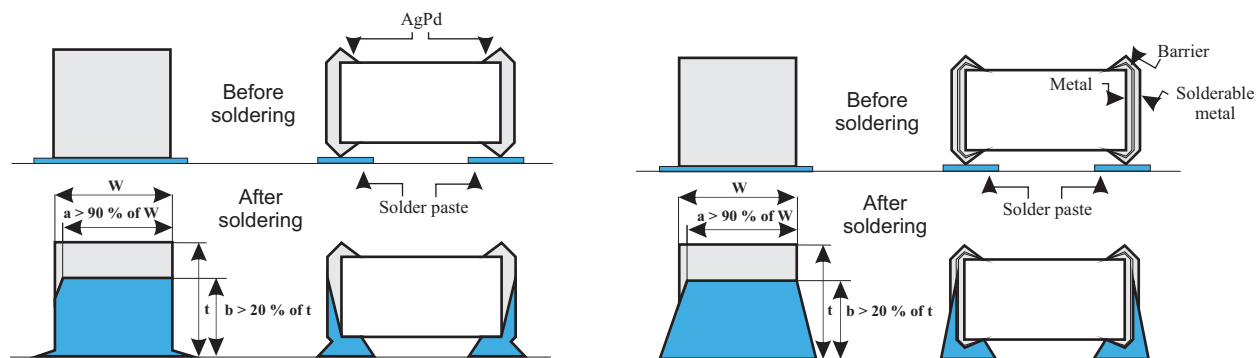

Fig. 5 Soldering Criterion in case of Wave and IR Reflow Pb-free Soldering

Pb-free Wave and IR Reflow Soldering – typical “before” and “after” soldering results for Silver/Palladium (AgPd) and Barrier Type End Terminations are given in A phenomenon known as “mirror” or “negative” meniscus results will appear in the case of Silver/Palladium terminated varistors. Solder forms a metallurgical junction with the entire volume of the end termination, i.e. it diffuses from pad to end termination across the inner side, forming a “mirror” or “negative meniscus. The height of the solder penetration can be clearly seen on the end termination and is always 30% higher than the chip height.

Since barrier type terminations on KEKO-VARICON chips do not require the use of problematic nickel and tin-alloy electroplating processes, these varistors are truly considered environmentally friendly.

Solder Test and Retained Samples – reflow soldering test based on J-STD-020D.1 and soldering test by dipping based on IEC 60068-2 for Pb-free solders are performed on each production lot as shown in the following chart. Test results and accompanying samples are retained for a minimum of two (2) years. The solderability of a specific lot can be checked at any time within this period should a customer require this information.

| Test | Resistance to flux | Solderability | Static leaching (simulation of Reflow Soldering) | Dynamic leaching (simulation of Wave Soldering) |
|------------------------------------|--|---|--|--|
| Parameter | | | | |
| Soldering method | dipping | dipping | dipping | dipping with agitation |
| Flux | L3CN, ORLO | L3CN, ORLO, R | L3CN, ORLO, R | L3CN, ORLO, R |
| Pb Solder | 62Sn / 36Pb / 2 Ag | | | |
| Pb Soldering temperature (°C) | 235 ± 5 | 235 ± 5 | 260 ± 5 | 235 ± 5 |
| Pb-FREE Solder | Sn96 / Cu0,4-0,8 / 3-4Ag | | | |
| Pb-FREE Soldering temperature (°C) | 250 ± 5 | 250 ± 5 | 280 ± 5 | 250 ± 5 |
| Soldering time (s) | 2 | 210 | 10 | > 15 |
| Burn-in conditions | V _{dcmax} , 48 h | - | - | - |
| Acceptance criterion | dVn < 5 %, i _{dc} must stay unchanged | > 95 % of end termination must be covered by solder | > 95 % of end termination must be intact and covered by solder | > 95 % of end termination must be intact and covered by solder |

Rework Criteria Soldering Iron – unless absolutely necessary, the use of soldering irons is NOT recommended for reworking varistor chips. If no other means of rework is available, the following criteria must be strictly followed:

- Do not allow the tip of the iron to directly contact the top of the chip
- Do not exceed the following soldering iron specifications:
 - Output Power: 30 Watts maximum
 - Temperature of Soldering Iron Tip: 280 °C maximum
 - Soldering Time: 10 Seconds maximum

Storage Conditions – SMD varistors should be used within 1 year of purchase to avoid possible soldering problems caused by oxidized terminals. The storage environment should be controlled, with humidity less than 40% and temperature between -25 and 45 °C. Varistor chips should always be stored in their original packaged unit.

Where varistor chips have been in storage for more than 1 year, and where there is evidence of solderability difficulties, KEKO-VARICON can “refresh” the terminations to eliminate these problems.

Reliability Testing Procedures

Varistor testing procedures comply with CECC 42200, IEC 1051-1/2 and AEC-Q200.

Testing results are available upon customer request. Special tests can be performed upon customer request.

| Reliability Parameter | Test | Tested according to | Condition to be satisfied after testing |
|---------------------------------------|---|---|--|
| AC/DC Bias Reliability | AC/DC Life Test | CECC 42200, Test 4.20 or IEC 1051-1, Test 4.20., AEC-Q200 Test8 - 1000 h at UCT | $ \delta_{Vn} (1 \text{ mA}) < 10 \%$ |
| Pulse Current Capability | $I_{\text{max}} 8/20 \mu\text{s}$ | CECC 42200, Test C 2.1 or IEC 1051-1, Test 4.5. 10 pulses in the same direction at 2 pulses per minute at maximum peak current for 10 pulses | $ \delta_{Vn} (1 \text{ mA}) < 10 \%$ no visible damage |
| Pulse Energy Capability | $W_{\text{max}} 10/1000 \mu\text{s}$ | CECC 42200, Test C 2.1 or IEC 1051-1, Test 4.5. 10 pulses in the same direction at 1 pulse every 2 minutes at maximum peak current for 10 pulses | $ \delta_{Vn} (1 \text{ mA}) < 10 \%$ no visible damage |
| WLD Capability | WLD x 10 | ISO 7637, Test pulse 5, 10 pulses at rate 1 per minute | $ \delta_{Vn} (1 \text{ mA}) < 15 \%$ no visible damage |
| V_{jump} Capability | $V_{\text{jump}} 5 \text{ min}$ | Increase of supply voltage to $V \geq V_{\text{jump}}$ for 1 minute | $ \delta_{Vn} (1 \text{ mA}) < 15 \%$ no visible damage |
| Environmental and Storage Reliability | Climatic Sequence | CECC 42200, Test 4.16 or IEC 1051-1, Test 4.17. a) Dry heat, 16h, UCT, Test Ba, IEC 68-2-2 b) Damp heat, cyclic, the first cycle: 55 °C, 93 % RH, 24 h, Test Db 68-2-4 c) Cold, LCT, 2 h, Test Aa, IEC 68-2-1 d) Damp heat cyclic, remaining 5 cycles: 55 °C, 93 % RH, 24 h/cycle, Test Bd, IEC 68-2-30 | $ \delta_{Vn} (1 \text{ mA}) < 10 \%$ |
| | Thermal Shock | CECC 42200, Test 4.12, Test Na, IEC 68-2-14, AEC-Q200 Test16, 5 cycles UCT/LCT, 30 minutes | $ \delta_{Vn} (1 \text{ mA}) < 10 \%$ no visible damage |
| | Steady State Damp Heat | CECC 42200, Test 4.17, Test Ca, IEC 68-2-3, AEC-Q200 Test 6, 56 days, 40 °C, 93% RH. AEC-Q200 Test7: Bias, Rh, T all at 85. | $ \delta_{Vn} (1 \text{ mA}) < 10 \%$ |
| | Storage Test | IEC 68-2-2, Test Ba, AEC-Q200 Test 3, 1000 h at maximum storage temperature | $ \delta_{Vn} (1 \text{ mA}) < 5 \%$ |
| Mechanical Reliability | Solderability | CECC 42200, Test 4.10.1, Test Ta, IEC 68-2-20 solder bath and reflow method | Solderable at shipment and after 2 year of storage, criteria > 95% must be covered by solder for reflow meniscus |
| | Resistance to Soldering Heat | CECC 42200, Test 4.10.2, Test Tb, IEC 68-2-20 solder bath nad reflow method | $ \delta_{Vn} (1 \text{ mA}) < 5 \%$ |
| | Terminal Strength | JIS-C-6429, App. 1, 18N for 60 s - same for AEC-Q200 Test 22 | no visual damage |
| | Board Flex | JIS-C-6429, App. 2, 2 mm min. AEC-Q200 test 21 - Board flex: 2 mm flex min. | $ \delta_{Vn} (1 \text{ mA}) < 2 \%$ no visible damage |
| | Vibration | CECC 42200, Test 4.15, Test Fc, IEC 68-2-6, AEC-Q200 Test 14. Frequency range 10 to 55 Hz (AEC: 10-2000Hz) Amplitude 0.75 m/s ² or 98 m/s ² (AEC: 5 g's for 20 minutes) Total duration 6 h (3x2h) (AEC: 12 cycles each of 3 directions) Waveshape - half sine | $ \delta_{Vn} (1 \text{ mA}) < 10 \%$ no visible damage |
| Mechanical Shock | CECC 42200, Test 4.14, Test Ea, IEC 68-2-27, AEC-Q200 Test 13. Acceleration = 490 m/s ² (AEC: MIL-STD-202-Method 213), Pulse duration = 11 ms, Waveshape - half sine; Number of shocks = 3x6 | $ \delta_{Vn} (1 \text{ mA}) < 10 \%$ no visible damage | |
| Electrical Transient Conduction | ISO-7637-1 Pulses | AEC-Q200 Test 30: Test pulses 1 to 3. Also other pulses - freestyle. | $ \delta_{Vn} (1 \text{ mA}) < 10 \%$ no visible damage |

Terminology

| Term | Symbol | Definition |
|---|---------------|---|
| Rated AC Voltage | V_{rms} | Maximum continuous sinusoidal AC voltage (<5% total harmonic distortion) which may be applied to the component under continuous operation conditions at 25 °C |
| Rated DC Voltage | V_{dc} | Maximum continuous DC voltage (<5% ripple) which may be applied to the component under continuous operating conditions at 25 °C |
| Supply Voltage | V | The voltage by which the system is designated and to which certain operating characteristics of the system are referred; $V_{rms} = 1,1 \times V$ |
| Leakage Current | I_{dc} | The current passing through the varistor at V_{dc} and at 25 °C or at any other specified temperature |
| Varistor Voltage | V_n | Voltage across the varistor measured at a given reference current I_n |
| Reference Current | I_n | Reference current = 1 mA DC |
| Clamping Voltage Protection Level | V_c | The peak voltage developed across the varistor under standard atmospheric conditions, when passing an 8/20 μ s class current pulse |
| Class Current | I_c | A peak value of current which is 1/10 of the maximum peak current for 100 pulses at two per minute for the 8/20 μ s pulse |
| Voltage Clamping Ratio | V_c/V_{app} | A figure of merit measure of the varistor clamping effectiveness as defined by the symbols V_c/V_{app} , where ($V_{app} = V_{rms}$ or V_{dc}) |
| Jump Start Transient | V_{jump} | The jump start transient results from the temporary application of an overvoltage in excess of the rated battery voltage. The circuit power supply may be subjected to a temporary overvoltage condition due to the voltage regulation failing or it may be deliberately generated when it becomes necessary to boost start the car. |
| Rated Single Pulse Transient Energy | W_{max} | Energy which may be dissipated for a single 10/1000 μ s pulse of a maximum rated current, with rated AC voltage or rated DC voltage also applied, without causing device failure |
| Load Dump Transient | WLD | Load Dump is a transient which occurs in automotive environment. It is an exponentially decaying positive voltage which occurs in the event of a battery disconnect while the alternator is still generating charging current with other loads remaining on the alternator circuit at the time of battery disconnect. |
| Rated Peak Single Pulse Transient Current | I_{max} | Maximum peak current which may be applied for a single 8/20 μ s pulse, with, rated line voltage also applies, without causing device failure |
| Rated Transient Average Power Dissipation | P | Maximum average power which may be dissipated due to a group of pulses occurring within a specified isolated time period, without causing device failure at 25 °C |
| Capacitance | C | Capacitance between two terminals of the varistor measured at @ 1 kHz |
| Non-linearity Exponent | α | A measure of varistor nonlinearity between two given operating currents, I_n and I_1 , as described by $I = k V \exp(a)$, where: - k is a device constant, - $I_1 < I < I_n$ and - $a = 0 \log(I_1/I_n) / \log(V_1/V_n) = 1 / \log(V_1/V_n)$, where: - I_n is reference current (1 mA) and V_n is varistor voltage - $I_1 = 10 I_n$, V_1 is the voltage measured at I_1 |
| Response Time | t_r | The time lag between application of a surge and varistor's "turn-on" conduction action |
| Varistor Voltage Temperature Coefficient | TC | $(V_n \text{ at } 85 \text{ }^\circ\text{C} - V_n \text{ at } 25 \text{ }^\circ\text{C}) / (V_n \text{ at } 25 \text{ }^\circ\text{C}) \times 60 \text{ }^\circ\text{C}) \times 100$ |
| Insulation Resistance | IR | Minimum resistance between shorted terminals and varistor surface |
| Isolation Voltage | | The maximum peak voltage which may be applied under continuous operating conditions between the varistor terminations and any conducting mounting surface |
| Operating Temperature | | the range of ambient temperature for which the varistor is designed to operate continuously as defined by the temperature limits of its climatic category |
| Climatic Category | LCT/UCT/DHD | UCT = Upper Category Temperature - the maximum ambient temperature for which a varistor has been designed to operate continuously, LCT = Lower Category Temperature - the minimum ambient temperature at which a varistor has been designed to operate continuously DHD = Dump Heat Test Duration |
| Storage Temperature | | Storage temperature range without voltage applied |
| Current/Energy Derating | | Derating of maximum values when operated above UCT (85 °C for PV and 125 °C for DV) |

KEKOVARICON

Grajski trg 15, SI-8360 Zuzemberk, SLOVENIA

Phone: + 386 7 3885 178

Fax: + 386 7 3885 166

E-mail: info@keko-varicon.si

All rights reserved/Copyright © 2015 KEKO VARICON d.o.o.

www.keko-varicon.si